

MODEL 259

3-Phase Monitor

- DPDT 600VAC Output Contacts
- Adjustable Trip & Restart Delays
- Adjustable Voltage Level
- 5 Year Unconditional Warranty

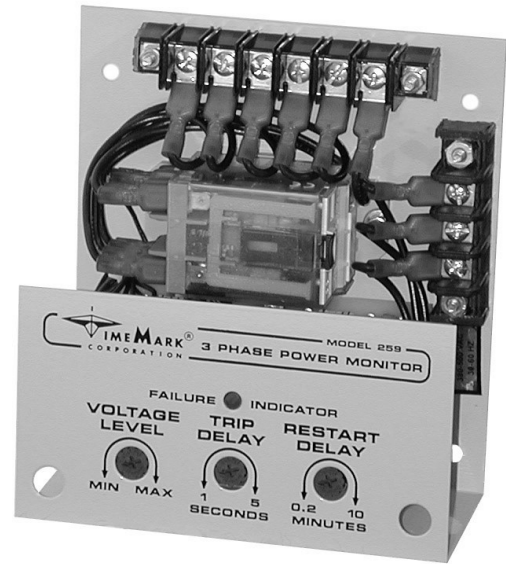

DESCRIPTION

The **Model 259 3-Phase Monitor** is designed to protect individual 3-phase equipment and motors, when used alone or in conjunction with shunt trip breakers. When correct voltage and phase rotation are applied an internal DPDT relay energizes.

A fault condition (phase loss, phase reversal, or low voltage) drops out the relay and lights the LED failure indicator. The Model 259 will detect a phase loss condition even when regenerative voltage is present.

The Model 259 may be used with Wye or Delta systems and requires no neutral connection. Standard operating ranges are available from 120 to 575 VAC, 60Hz and 380VAC, 50Hz.

SPECIFICATIONS

Model	A259	B259	C259	D259	EX259
Nominal AC Voltage (phase to phase)	120VAC	208/240VAC	480VAC	575VAC	380VAC
Adjust Range (VAC)	85-125	160-260	380-500	450-600	300-400
Frequency	60Hz				50Hz
Power Consumption	2.1W	3.3W	4.2W	6.9W	4.2W
Transient Protection	2500V for 10ms				
Repeat Accuracy	± 0.1 % (fixed conditions)				
Response Time	Adjustable 1 to 5 seconds				
Reset Time	Adjustable 0.2 to 10 minutes				
Reset Type	Automatic				
Dead Band	Approximately 2%				
Output Contacts	DPDT	3A at 480/600VAC 10A at 240VAC	80% PF 80% PF resistive		
Expected Relay Life	Mech: 10 million operations Elec: 100,000 operations at rated load				
Operating Temp	- 20° to +131° F				
Humidity Tolerance	0-97% w/o condensation				
Enclosure Material	20 gauge steel				
Mounting	Surface				
Weight	17 oz.				

DIMENSIONS

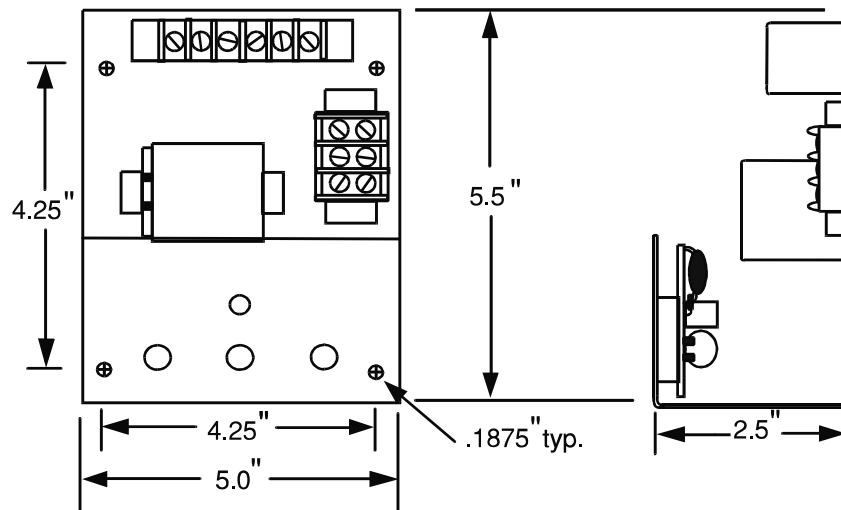

TIME MARK
CORPORATION

11/2011
© 2011 TIME MARK CORPORATION

TIME MARK is a division of  AEMT, Inc.

MODEL 259 3-Phase Monitor

READ ALL INSTRUCTIONS BEFORE INSTALLING, OPERATING OR SERVICING THIS DEVICE.
KEEP THIS DATA SHEET FOR FUTURE REFERENCE.

GENERAL SAFETY

POTENTIALLY HAZARDOUS VOLTAGES ARE PRESENT AT THE TERMINALS OF THE MODEL 259.
ALL ELECTRICAL POWER SHOULD BE REMOVED WHEN CONNECTING OR DISCONNECTING WIRING.
THIS DEVICE SHOULD BE INSTALLED AND SERVICED BY QUALIFIED PERSONNEL.

Installation Instructions

INSTALLATION

Connect the 3-phase wiring to the terminals marked L1, L2, L3.

Connect the control wiring to the terminals with the contact markings (refer to the diagram on the unit). The markings shown on the unit are the failed condition of the contacts.

Apply power. If the contacts do not transfer (FAILURE INDICATOR=Off), check that all three phases are present and of the correct voltage. If all phases are correct, rotate the VOLTAGE LEVEL adjustment counter-clockwise to the MIN position.

If the contacts still do not transfer, remove power from the unit. Reverse two of the three input wires and re-apply power. The contacts should transfer to the normal condition (normally-open contacts closed, FAILURE INDICATOR=Off).

Note: Upon initial power up with proper voltage and phase sequence it will take about 12 seconds before the trip led will go out and the contacts will transfer to the normal state.

When making voltage level adjustments after the unit is tripped the above will apply.

ADJUSTMENT

Note: During adjustment you may want to install a jumper across the control contacts to prevent cycling the load on and off.

Set the TRIP DELAY to 1 second. Rotate the VOLTAGE LEVEL adjustment slowly clockwise, until the contacts transfer to the failed condition (FAILURE INDICATOR=On). Slowly turn the adjustment counterclockwise until the contacts reset to the normal condition (FAILURE INDICATOR=Off).

Remove the jumper, if installed.

This setting will be correct for most applications. The trip delay will prevent most nuisance tripping; however, if nuisance tripping does occur, turn the VOLTAGE LEVEL slightly farther counter-clockwise.

In making adjustments to eliminate nuisance tripping, the VOLTAGE LEVEL adjustment should be rotated in very small increments until the true nuisance trips are eliminated. Adjust the TRIP DELAY setting, and RE-START DELAY as required for the application.

TYPICAL APPLICATION

Shunt Trip Breaker Operation

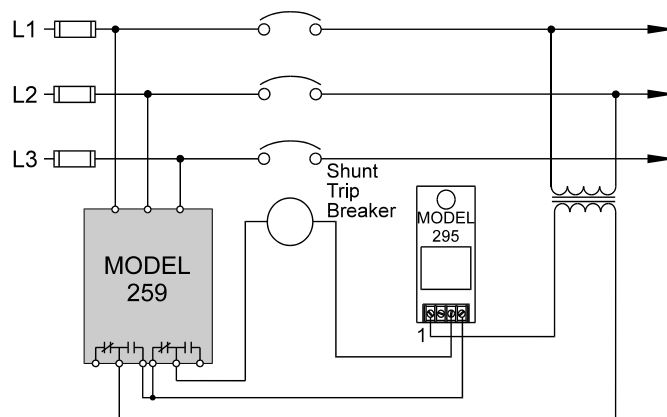

TYPICAL APPLICATION

Individual Motor Protection

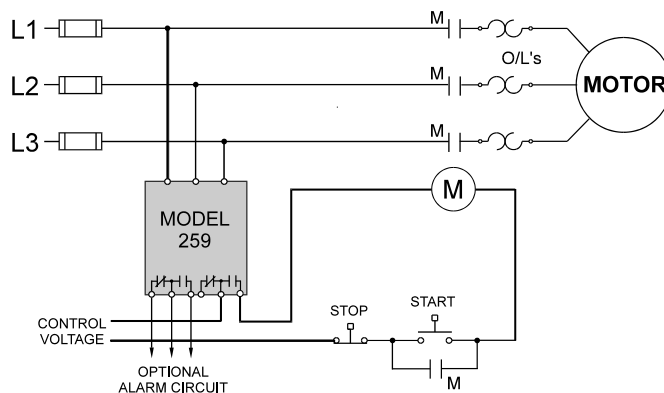

WARRANTY

This product is warranted to be free from defects in materials and workmanship, and is covered by our exclusive **5-year Unconditional Warranty**. Should this device fail to operate for any reason, we will repair it for five years from the date of manufacture. For complete warranty details, see the *Terms and Conditions of Sales* page in the front section of the Time Mark catalog or contact Time Mark at 1-800-862-2875.



TIME MARK
CORPORATION

11/2011

© 2011 TIME MARK CORPORATION

TIME MARK is a division of  AEMT, Inc.